

Robonova-1

2.4GHz wireless controller

#136080



- Assembly
- Button Example
- Button Command Table
- Vibration Function
- Vibration Command Table
- New template file

- Adapter board
- Compact and small size
 - RX/TX connection port
 - Combined with RF Transceiver
 - Working with 3024 controller board
 - full ETX command set for :
Analog/Digital value control
Pressure control
Motor vibration control

Assembly

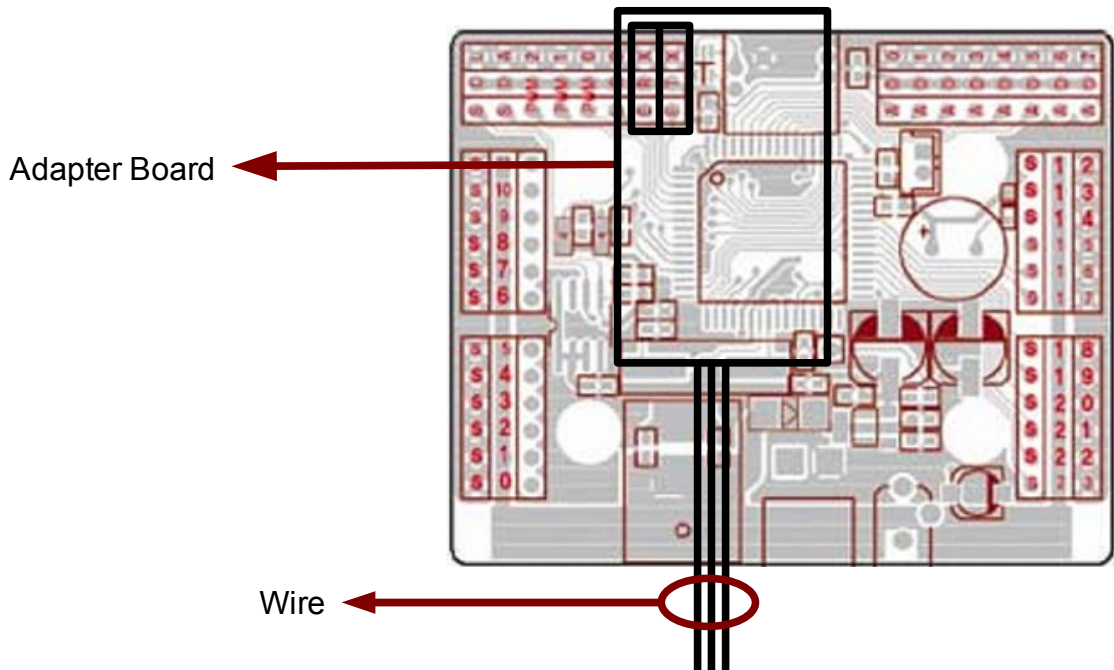
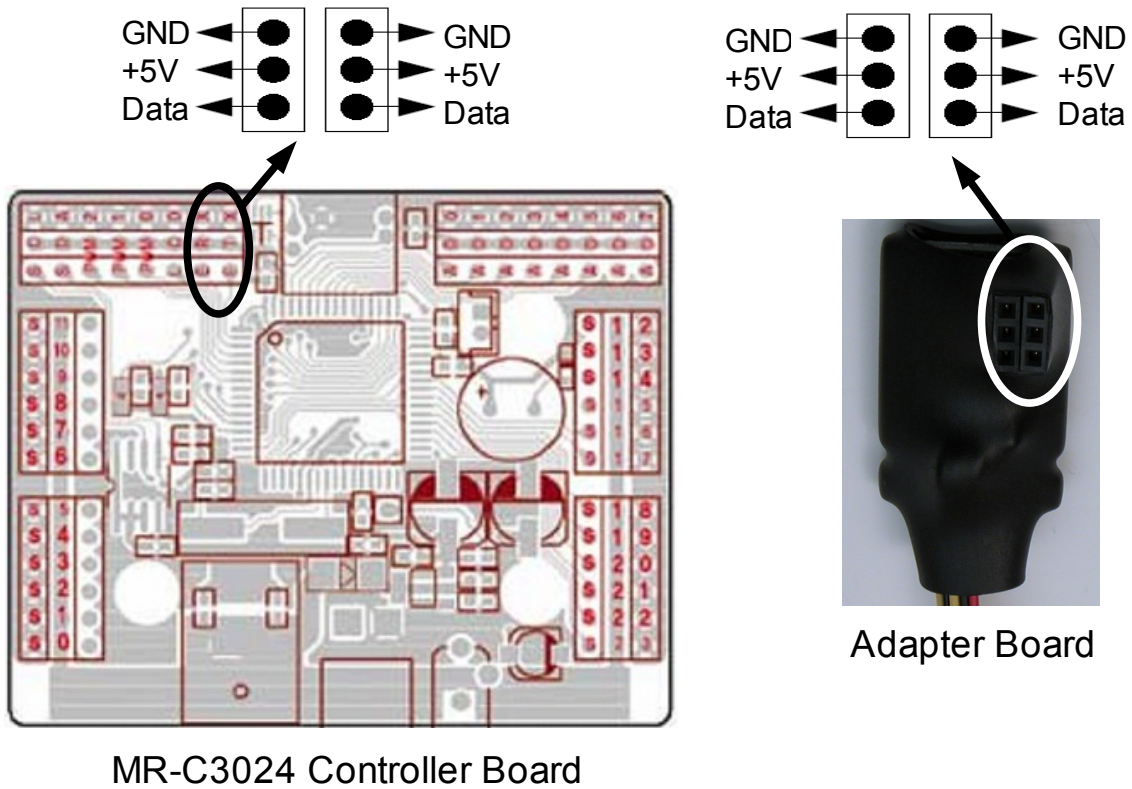

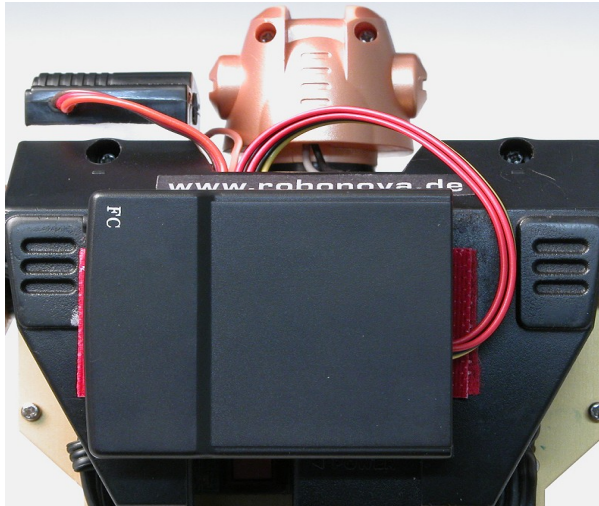

Assembly Example

Button Example



(Circle Button)

Send:
CHARACTER = b
Get:
Byte = 1
Bit = 5

DIM circle AS BYTE
DIM b AS BYTE
DIM char AS BYTE

char = "b"

ETX 19200,char

↓ ↓ ↓
Sent Boudrate character b

ERX 19200,byte1,movelist

↓ ↓ ↓
Receive Byte 1 Goto movelist

movelist:

circle = byte1.5

↓ ↓ ↓
Button Circle Byte 1 Bit 5

IF circle = 0 THEN GOTO move

move:

MOVE G6D, 85, 71, 152, 91, 112, 60

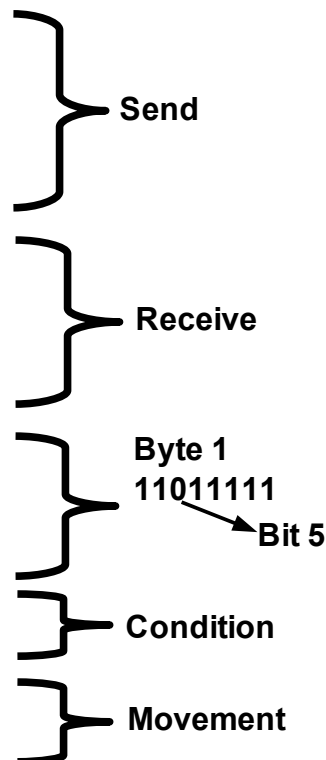

Button Command Table

Character Sent	Get Byte	Single Bit	Button
"a"	0	0	Select
		1	L3
		2	R3
		3	Start
		4	Up
		5	Right
		6	Down
		7	Left

"b"	1	0	L2
		1	R2
		2	L1
		3	R1
		4	Triangle
		5	Circle
		6	Cross
		7	Square

			Analog	
"c"	2	-	Right Analog	0x00 = Left 0xFF = Right
"d"	3	-	Right Analog	0x00 = Up 0xFF = Down
"e"	4	-	Left Analog	0x00 = Left 0xFF = Right
"f"	5	-	Left Analog	0x00 = Up 0xFF = Down

			Button	Pressure
"g"	6	-	Pressure Right	0x00 = none 0xFF = full
"h"	7	-	Pressure Left	0x00 = none 0xFF = full
"i"	8	-	Pressure Up	0x00 = none 0xFF = full
"j"	9	-	Pressure Down	0x00 = none 0xFF = full
"k"	10	-	Pressure Triangle	0x00 = none 0xFF = full
"l"	11	-	Pressure Circle	0x00 = none 0xFF = full
"m"	12	-	Pressure Cross	0x00 = none 0xFF = full
"n"	13	-	Pressure Square	0x00 = none 0xFF = full
"o"	14	-	Pressure L1	0x00 = none 0xFF = full
"p"	15	-	Pressure R1	0x00 = none 0xFF = full
"q"	16	-	Pressure L2	0x00 = none 0xFF = full
"r"	17	-	Pressure R2	0x00 = none 0xFF = full

Vibration Function



DIM F AS BYTE

DIM v AS BYTE

char = "F"
 ETX 19200,char (Send Character F for Left Vibration)

char = "v"
 ETX 19200,char (Send Character v for Right Vibration)

Vibration Command Table

Character Sent	“.”	“0”	“1”	“2”	“3”	“4”	“5”	“6”	“7”	“8”	“9”	“A”	“B”	“C”	“D”	“E”	“F”	“v”	
Left Motor		Off															Max		
Right Motor	Off																		Max

New template file

Please download here: 2.4GHz wireless controller template.bas

http://www.robonova.de/store/support/index.php?_m=downloads&_a=viewdownload&downloaditemid=154&nav=0,5,7