

NOTES: UNLESS OTHERWISE SPECIFIED
 1. ALL CAPACITOR VALUES ARE IN MICROFARADS.
 2. ALL RESISTOR VALUES ARE IN OHMS.

REV	BY	DATE
A	TB	091209

CHANNEL 1

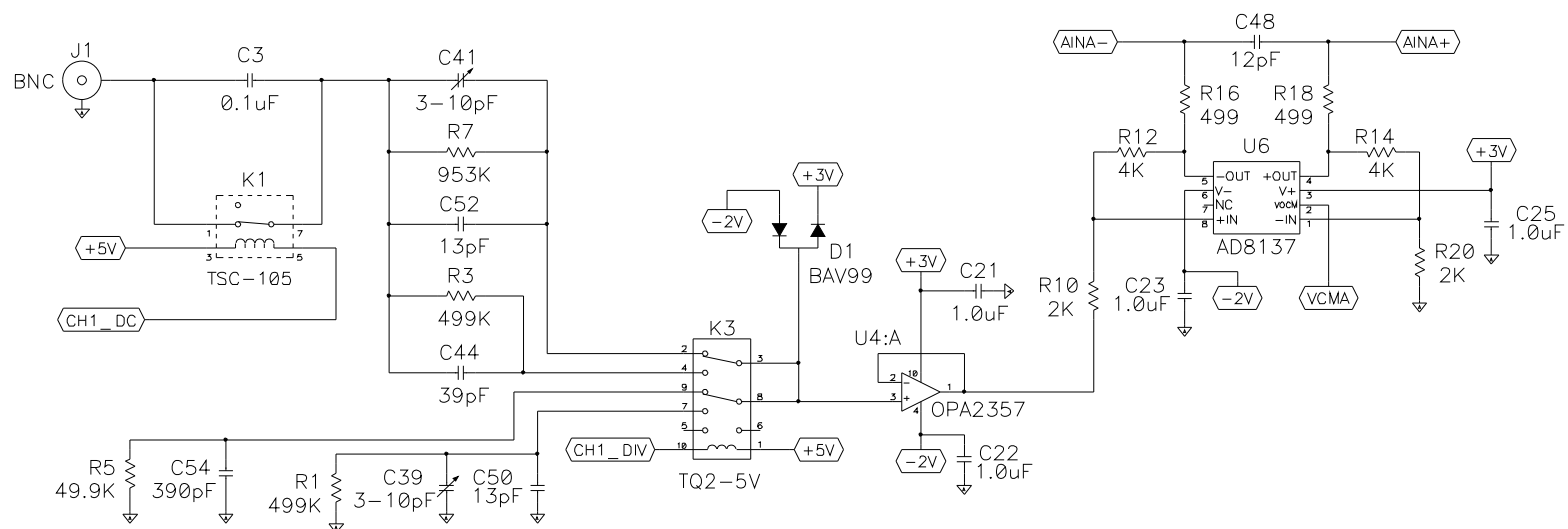

USB INTERFACE

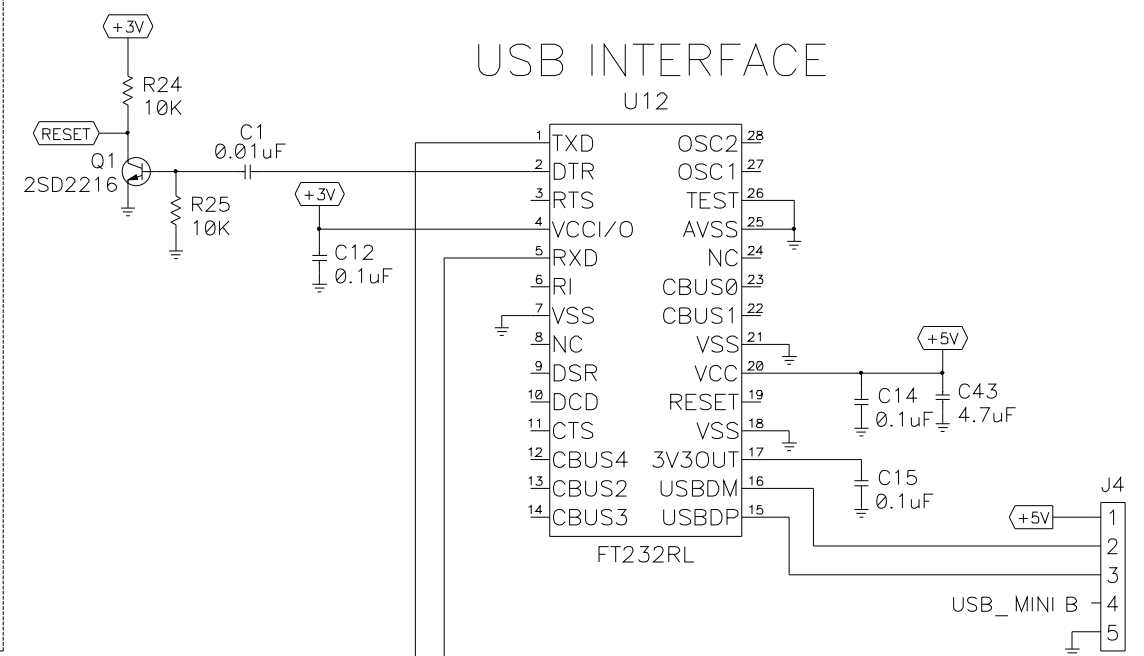

ADC

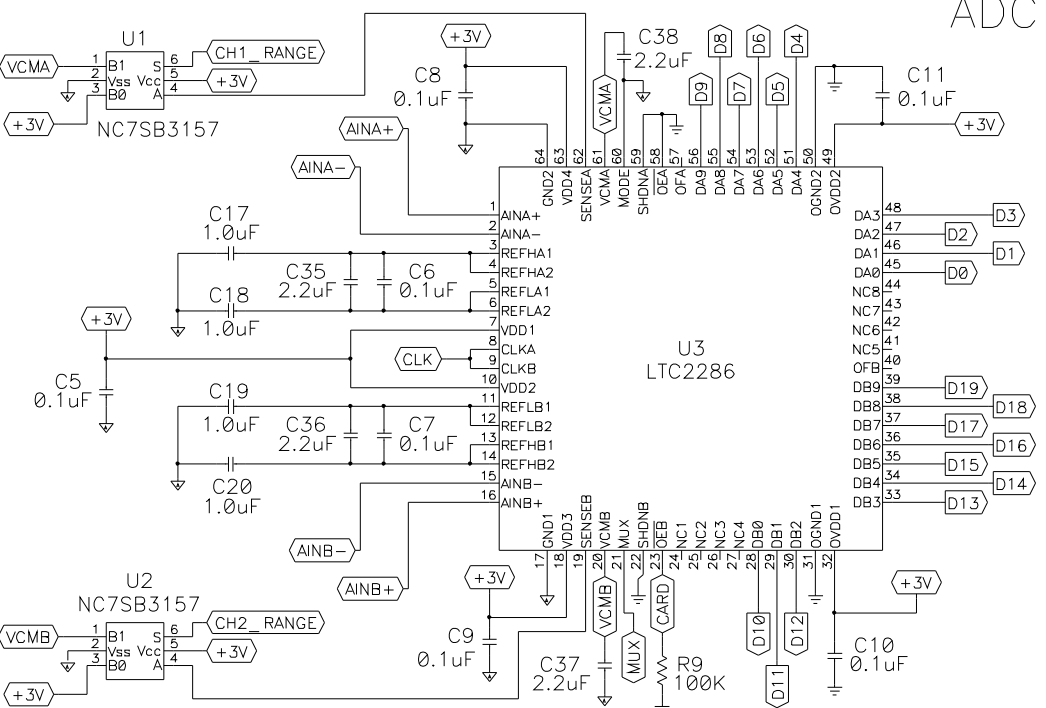

PROPELLER

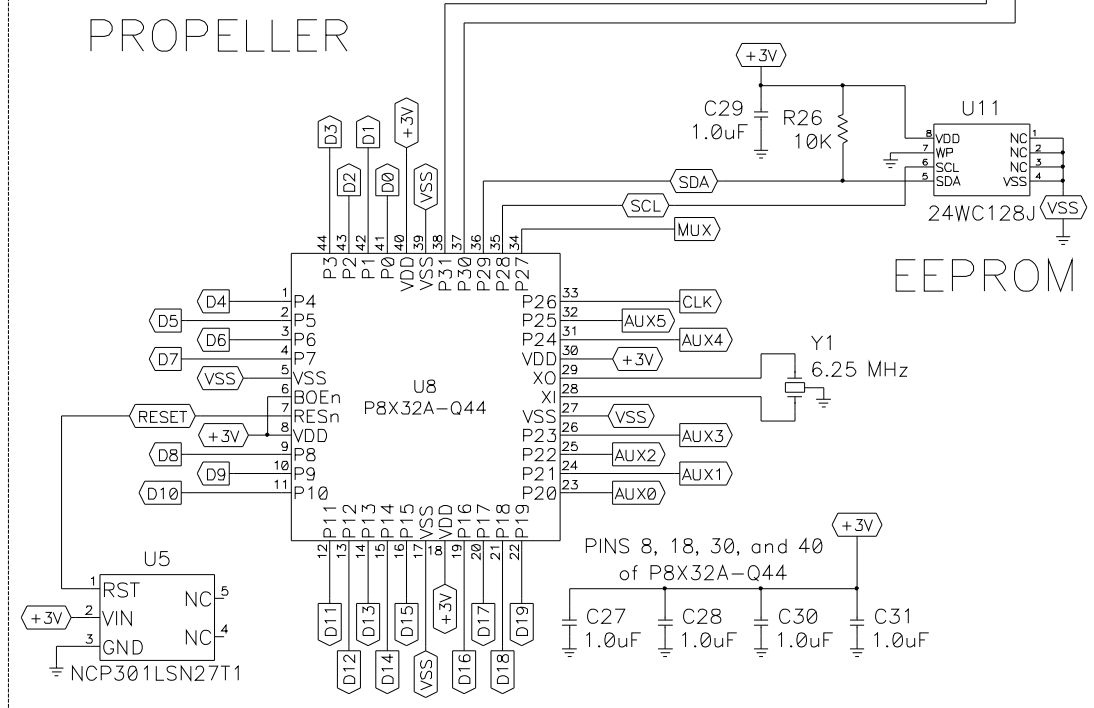

EXPANSION CONNECTOR

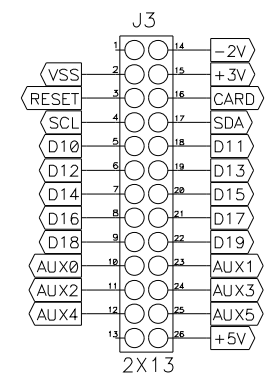

-2V REGULATOR

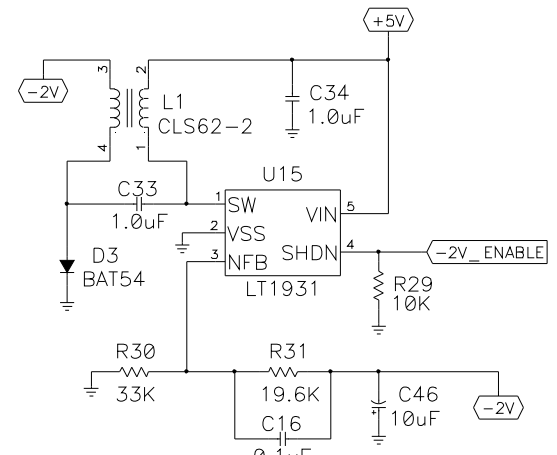

CHANNEL 2

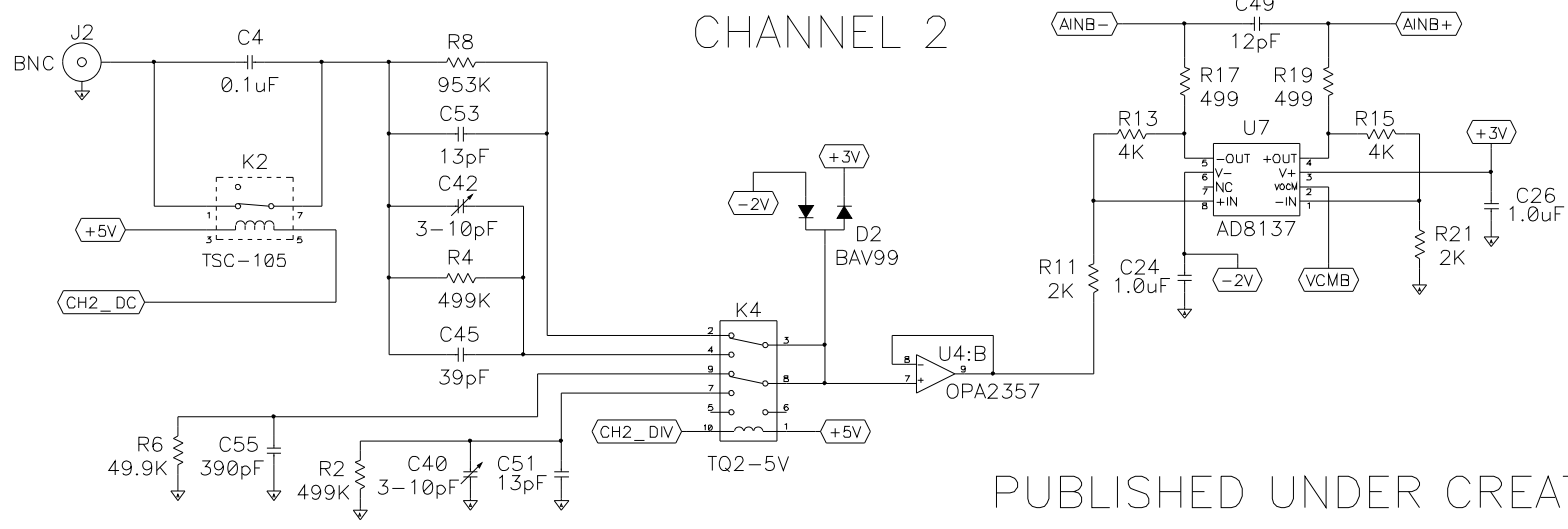

I/O EXPANDER

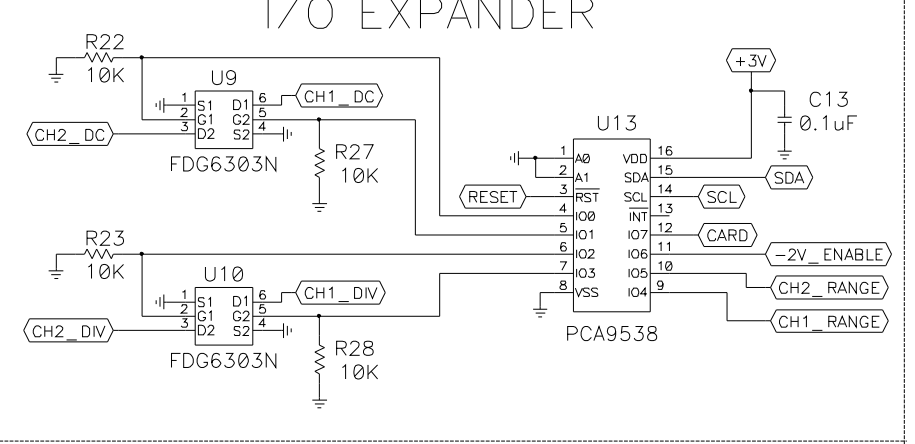

+3V REGULATOR

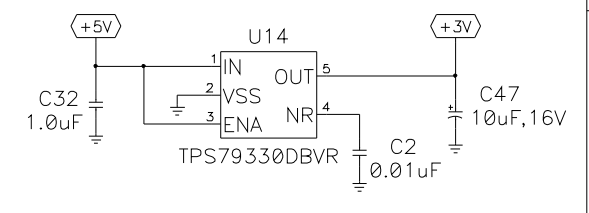

PUBLISHED UNDER CREATIVE COMMONS LICENSE GUIDELINES

PARALLAX INC. ROCKLIN, CA 95765 (916) 624-8333		
TITLE SCHEMATIC, PROPSCOPE		
SIZE D	DWG. NO. 32220	REV. A
SCALE NONE	SHEET 1 OF 1	